

E-3 E User Guide

Phono Equalizer Amplifier

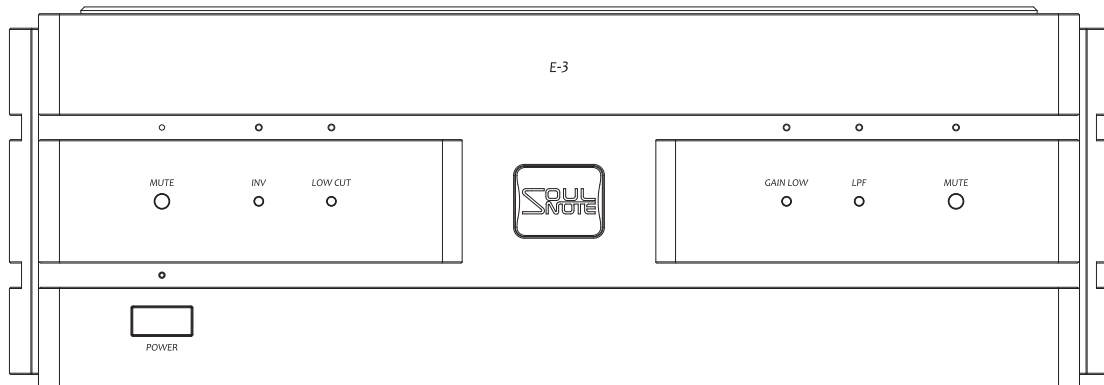

Table of Contents

Safety Precautions.....	3
Front Panel Names and Functions	6
Rear Panel Names and Functions.....	7
Features of This Product	8
Balanced Output.....	9
Attaching the Spike Pins.....	9
Protection Pads for Transport.....	10
About Installation	10
Troubleshooting	11
Maintenance	11
Specifications.....	11

Supplied Accessories

• User Guide (this manual)	1	• Spike pin	3
• Power cable	1	• Hex key for spike pins	1
• Spike-receiving board	1		
• Setting spacer	3		

Safety Precautions



CAUTION

RISK OF ELECTRIC SHOCK
DO NOT OPEN



CAUTION: TO REDUCE THE RISK OF ELECTRIC SHOCK, DO NOT REMOVE COVER (OR BACK). NO USER-SERVICEABLE PARTS INSIDE. REFER SERVICING TO QUALIFIED SERVICE PERSONNEL.



The lightning flash with arrowhead symbol, within an equilateral triangle, is intended to alert the user to the presence of uninsulated “dangerous voltage” within the product’s enclosure that may be of sufficient magnitude to constitute a risk of electric shock to persons.



The exclamation point within an equilateral triangle is intended to alert the user to the presence of important operating and maintenance (servicing) instructions in the literature accompanying the product.

WARNING

TO REDUCE THE RISK OF FIRE OR ELECTRIC SHOCK, DO NOT EXPOSE THIS APPLIANCE TO RAIN OR MOISTURE.

A warning that an apparatus with CLASS I construction shall be connected to a MAINS socket outlet with a protective earthing connection.

IMPORTANT SAFETY INSTRUCTIONS
READ BEFORE OPERATING EQUIPMENT

This product was designed and manufactured to meet strict quality and safety standards. There are, however, some installation and operation precautions which you should be particularly aware of.

1. Read these instructions.
2. Keep these instructions.
3. Heed all warnings.
4. Follow all instructions.
5. Do not use this apparatus near water.
6. Clean only with dry cloth.
7. Do not block any ventilation openings.
Install in accordance with the manufacturer's instructions.
8. Do not install near any heat sources such as radiators, heat registers, stoves, or other apparatus (including amplifiers) that produce heat.
9. Protect the power cord from being walked on or pinched particularly at plugs, convenience receptacles, and the point where they exit from the apparatus.
10. Only use attachments/accessories specified by the manufacturer.
11. Use only with the cart, stand, tripod, bracket, or table specified by the manufacturer, or sold with the apparatus. When a cart is used, use caution when moving the cart/apparatus combination to avoid injury from tip-over.
12. Unplug this apparatus during lightning storms or when unused for long periods of time.
13. Refer all servicing to qualified service personnel. Servicing is required when the apparatus has been damaged in any way, such as power-supply cord or plug is damaged, liquid has been spilled or objects have fallen into the apparatus, the apparatus has been exposed to rain or moisture, does not operate normally, or has been dropped.
14. Batteries shall not be exposed to excessive heat such as sunshine, fire or the like.



CAUTION:

- To completely disconnect this product from the mains, disconnect the plug from the wall socket outlet. The mains plug is used to completely interrupt the power supply to the unit and must be within easy access by the user.
- Never use the unit with any other cord except the supplied power cord.

NOTE ON USE

WARNINGS

- Avoid high temperatures.
Allow for sufficient heat dispersion when installed in a rack.
- Handle the power cord carefully.
Hold the plug when unplugging the cord.
- Keep the unit free from moisture, water, and dust.
- Unplug the power cord when not using the unit for long periods of time.
- Do not obstruct the ventilation holes.
- Do not let foreign objects into the unit.
- Do not let insecticides, benzene, and thinner come in contact with the unit.
- Never disassemble or modify the unit in any way.
- Ventilation should not be impeded by covering the ventilation openings with items, such as newspapers, tablecloths or curtains.
- Naked flame sources such as lighted candles should not be placed on the unit.
- Observe and follow local regulations regarding battery disposal.
- Do not expose the unit to dripping or splashing fluids.
- Do not place objects filled with liquids, such as vases, on the unit.
- Do not handle the mains cord with wet hands.
- When the switch is in the OFF position, the equipment is not completely switched off from MAINS.
- The equipment shall be installed near the power supply so that the power supply is easily accessible.

DECLARATION OF CONFORMITY

We declare under our sole responsibility that this product, to which this declaration relates, is in conformity with the following standards:

EN60065, EN55032, EN55020.

Following the provisions of Low Voltage Directive 2014/35/EU and EMC Directive 2014/30/EU.

A NOTE ABOUT RECYCLING:

This product's packaging materials are recyclable and can be reused. Please dispose of any materials in accordance with the local recycling regulations. When discarding the unit, comply with local rules or regulations.

Batteries should never be thrown away or incinerated but disposed of in accordance with the local regulations concerning battery disposal. This product and the supplied accessories, excluding the batteries, constitute the applicable product according to the WEEE directive.



Pb

CAUTIONS ON INSTALLATION

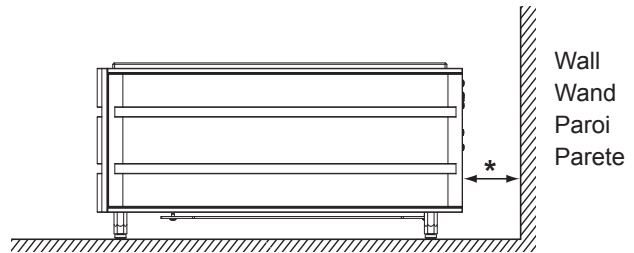
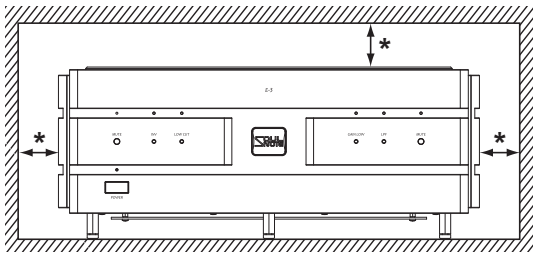

*** For proper heat dispersal, do not install this unit in a confined space, such as a bookcase or similar enclosure.**

- Leave sufficient clearance (at least 10 cm) from the wall, (at least 5 cm) from top surface of the unit.
- Do not place any other equipment on this unit.

Front Panel Names and Functions

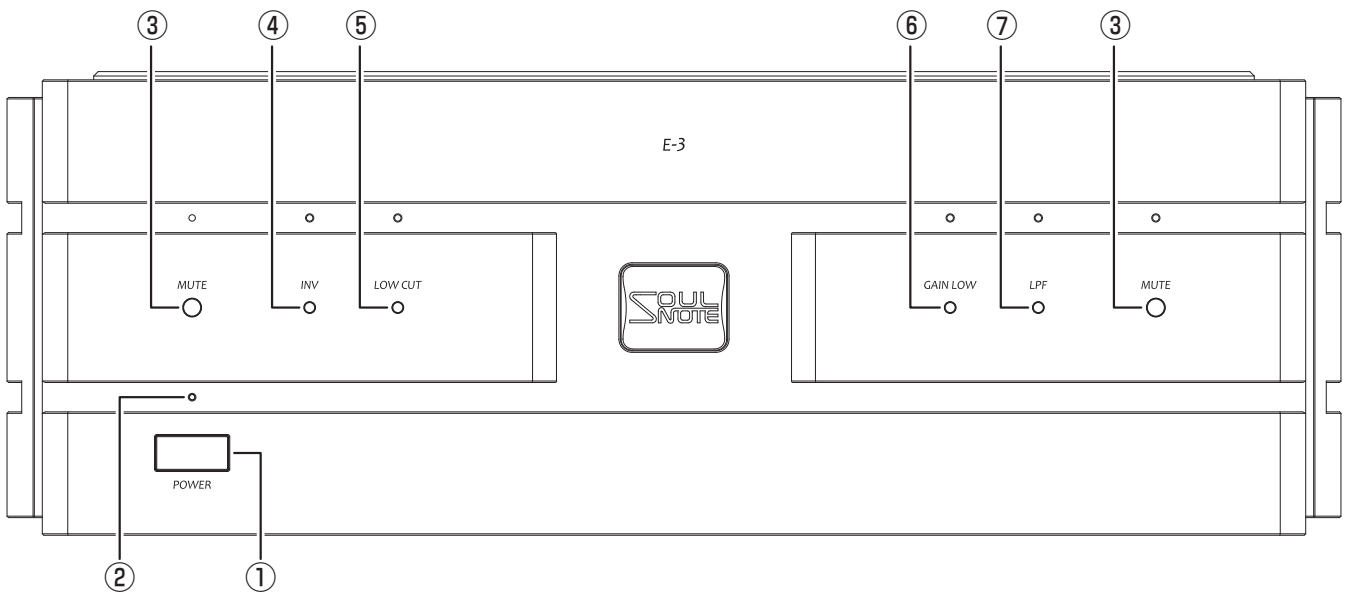

① Power Switch (POWER)

Press to turn on the power, and press again to turn off.

② Power Indicator (POWER)

The power is on, the indicator turns blue.

Note:

- When the GND switch on the rear panel is in the CONNECTION mode, the indicator is lit red.

③ Mute Button (MUTE)

Press the button to mute the sound, and press the same button again to cancel the mute. The same function buttons are located on the right and left sides of the front panel. Use whichever one suits the installation location of your record player.

To cancel the mute, be sure to use the same button you pressed to mute the sound. While muted, the LED above the button is lit yellow.

④ Phase Inversion Button (INV)

When this button is pressed, the LED lights up inverting output phase. Press again to cancel the phase inversion. After the button operation, no sound is output for about 5 seconds.

⑤ Low-cut Button (LOW CUT)

When this button is pressed, the LED lights up cutting out ultra-low range noise. Press again to cancel the setting. This function is intended to be used when the speaker woofer moves a lot due to, for example, curve of a record.

After the button operation, no sound is output for about 5 seconds.

⑥ Gain Low Button (GAIN LOW)

When this button is pressed, the LED lights up enabling you to lower the output level by 7dB. Press again to cancel the setting. About 5 seconds is required for sound to be output after the button operation. This function is intended to be used when sound is distorted because input goes over the maximum allowable input level (headroom) of the connected preamplifier or other devices.

⑦ Low-Pass Filter Button (LPF)

Once the button is pressed, the LED turns on and the analog low-pass filter is enabled, cutting high frequency noise. Press the button again to disable this function.

After the button operation, no sound is output for about 5 seconds.

Rear Panel Names and Functions

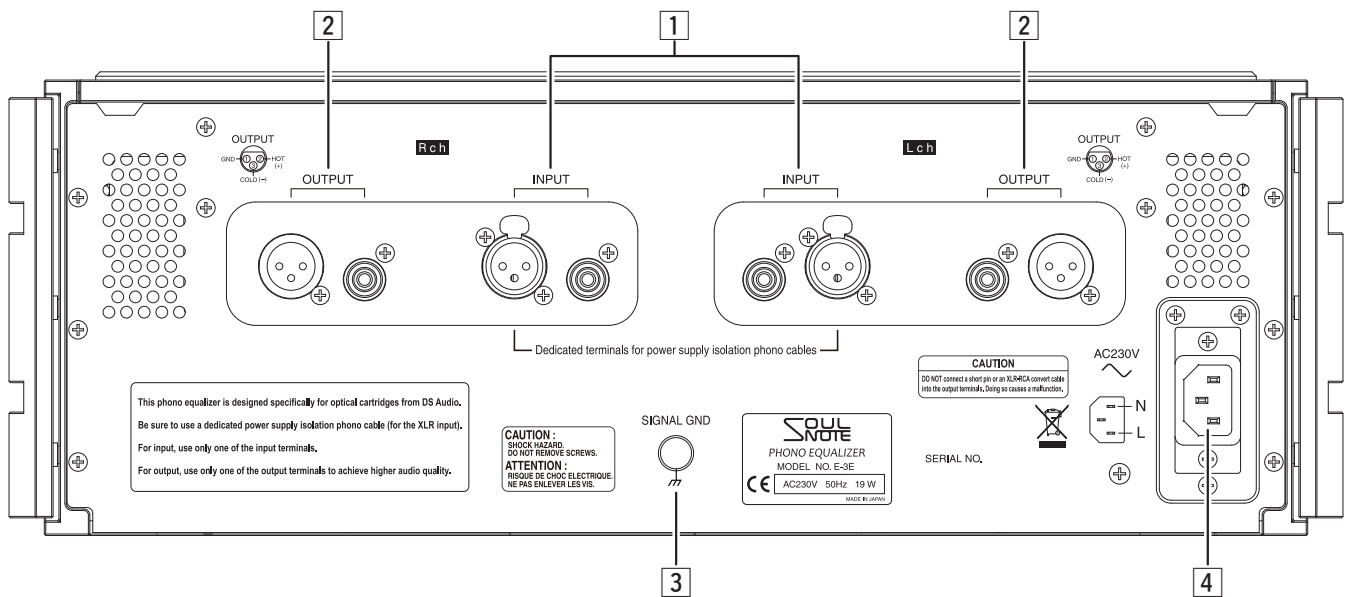

1 Audio Input Terminals (INPUT)

These are optoelectronic cartridge input terminals.

Note:

- As DC voltage is applied, never connect anything other than optoelectronic cartridges to these terminals
- The XLR terminals are dedicated for power supply isolation phono cables. Be sure to use dedicated cables.
- For input, use only one of the input terminals.

2 Output Terminals

Connect these to the line input terminals of devices such as a preamplifier and pre-main amplifier.

Balanced output terminal

Connect an XLR cable to these terminals.

Unbalanced output terminal

Connect an RCA cable to these terminals.

Note:

- For sound quality reasons, do not use balanced and unbalanced outputs at the same time. Also, even when not in use, merely connecting results in a capacitance load which can adversely affect the sound quality. Using balanced and unbalanced outputs at the same time will not cause a malfunction.

3 Grounding Terminals (SIGNAL GND)

Connect the grounding wire of each record player to these terminals.

4 AC Inlet (AC230V)

Connect to a 230 V AC wall outlet (mains) with the supplied power cable.

Notes:

- To maintain the audio quality, use the supplied power cable.
- Firmly insert the power cable into the end of the AC inlet.

⚠ Cautions

- **Do not use any electrical contact cleaner or the like in the AC inlet area.**

Features of This Product

Feature 1: A new Type-R circuit, fully balanced non NFB

Newly developed discrete, non-NFB, balanced amplification circuit (New Type-R circuit) dedicated to optical cartridges. Not only the voltage amplification, but also the output stage is a single system that operates entirely with respect to GND, eliminating push-pull and bias circuits. From input to output, the signal passes through only four transistors. A very simple non-NFB circuit protects the freshness of the music signal with excellent transient response of optical cartridges.

Feature 2: Super-strong power supply with 3 power transformers

The power supply consists of three transformers: a large transformer dedicated to the New Type-R Circuit with independent left and right circuits, and a transformer for the LED power supply of the optical cartridge. For a phono amplifier of only 19W, the power consumption has a power supply capacity equivalent to that of a 500W power amplifier. This margin supports unwavering music reproduction. A newly developed power transformer with copper short ring is used as the analog power transformer. This further improves the fine expression by suppressing noise caused by leakage flux.

Feature 3: Power Separated Phono Cable Compatible

The XLR input terminals are compatible with the "power supply separated phono cable" developed by DS Audio and Uesugi Laboratories. By separating the paths of the fine phono signal and LED current, the SN and dynamism that are the characteristics of optical cartridges are further improved.

Feature 4: High-speed non-NFB power supply

For the rectifying capacitor, a specially selected high withstand voltage small capacitance low magnification foil filter capacitor is used. To optimize the capacity, the number of units used was determined and the load on the power transformer was reduced. This further improved the real regulation of the ultra-powerful power transformer. For the rectifier diodes, SiC diodes of the latest specifications with enhanced allowable inrush current are used. This is the most powerful and high-speed power supply configuration ever considered. In addition, two large power relays with excellent sound quality are used independently and without fixing as power switches for the two main power transformer. In other words, the power switch on the front panel is dedicated to the control system sub-transformer. Independent power switch for each power transformer, which is a high current contact point, is very effective in terms of sound quality.

Feature 5: Unfixed structure

The amplifier block, terminals, AC inlet, top cover, and bottom cover are all unfixed.

Feature 6: RSR-2-12D (Reference SOULNOTE Relay)

An ultra low loss glass tube sealed reed relay that performs similar to a mercury relay as a base has been further customized. This is an original custom relay created by SOULNOTE that can reach sound quality levels comparable to that of wire. The E-3 uses the RSR-2-12D for all relays through which audio signals pass.

Feature 7: Ultra high-quality naked foil resistors

We have applied artificial satellite grade ultra-high precision foil resistors with exceptional temperature properties and have made additional customizations with an emphasis on sound quality. These ultra-high sound quality resistors were developed in-house and employ a naked foil design to eliminate dumps with mold resin. The E-3 uses ultra high-quality naked foil resistors for all resistors related to sound quality.

- For more detailed information, refer to our website or Facebook page.
https://www.kcsr.co.jp/eu_soulnote.html

Balanced Output

The XLR Connector is used for Balanced Output. There are two types of connection, “European Type” and “USA Type”.

1. European Type (adapter for this unit)

(pin 2 = HOT, pin 3 = COLD)

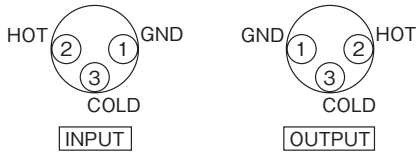

2. USA Type

(pin 2 = COLD, pin 3 = HOT)

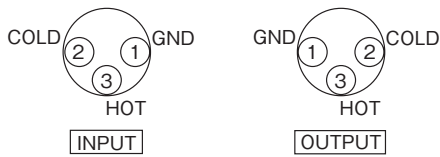

Attaching the Spike Pins

By replacing the feet with the supplied spike pins, you can tune the audio quality. Point grounding makes the sound focus and auditory lateralization sharper. Furthermore, the audio quality can be subtly tuned by changing the material of the surface on which this equipment is installed.

Notes:

- When replacing the feet with the spike pins, remove the carbon washers from the feet, and then reattach them to the spike pins.
- When the spike pins are attached, it may be difficult to keep weight balance stable. Take great care not to carelessly apply a force on the corners of the main unit.

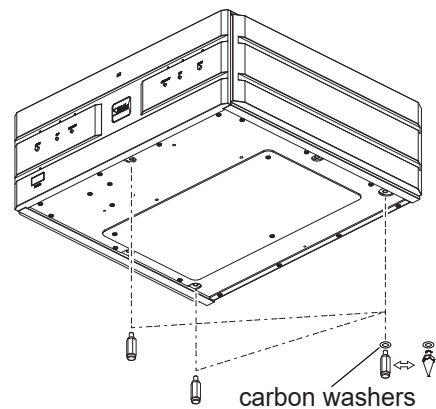

⚠ Cautions

- When using the spike pins, be extremely careful not to get injured, etc.
- When using the spike pins, be careful that the surface on which the main unit is installed such as the surface of a table, shelf, etc., may become damaged. Using the spike-receiving board is highly recommended in order to protect the installation surface.

Protection Pads for Transport

When unboxing this product, be sure to remove the transport cushions. With the cushions left attached, the intended sound quality of this product cannot be fully enjoyed.

- In order to obtain better sound quality, the top cover, the bottom cover, and the terminals on the rear panel are not secured.
- If you shake the unit, you will hear a rattling sound. It is not an abnormality.
- When you transport the unit, reattach the pads to the original places.

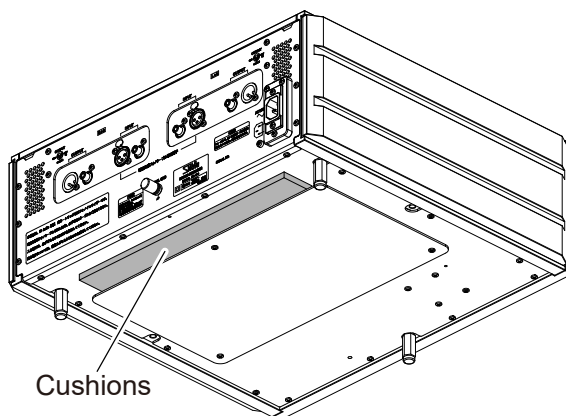
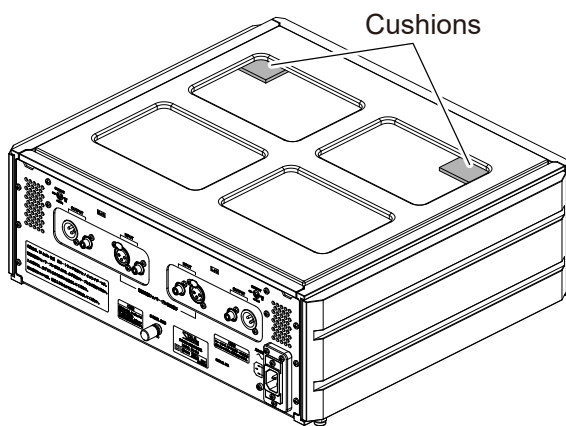

About Installation

When this product is installed on your shelf or audio rack with the spike pins attached, the supplied spike-receiving board can protect the installation surface from scratching.

Using the setting spacers along with the spike-receiving board ensures that there is space between the installation surface and the spike-receiving board. With that space, the air hole of the spike-receiving board can be utilized. This can further improve the sound quality.

The setting spacers can also be used alone as spike receivers.

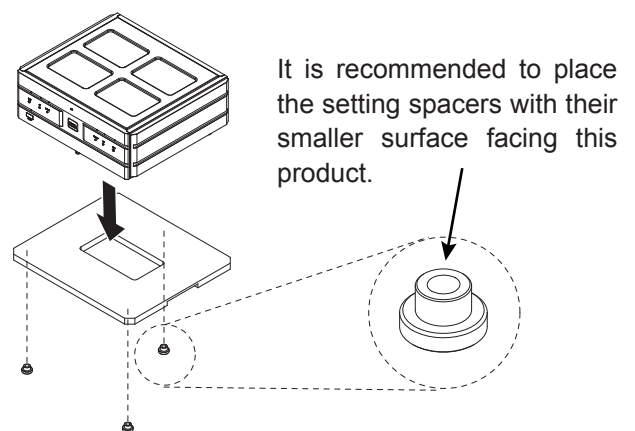

Troubleshooting

No sound is output.

- Check that the power of the main unit is on.
- Check the connections of the external devices.
- Check that the power of the external devices is on.
- Check that the operations and settings on the external devices are correct.
- Check the connections of the speaker system.

Maintenance

When the unit has become dirty, wipe it clean using a soft cloth. To remove stubborn stains, dilute some neutral dish-washing liquid in 5 or 6 times as much water, soak a soft cloth in the solution, wring it out well, wipe away the stains, and then wipe the surfaces dry with a dry cloth.

Never use alcohol, paint thinners, benzine, insecticides or other volatile substances since they may mar or remove the surface gloss.

Bear in mind that rubbing surfaces with a chemical cleaning cloth or leaving such a cloth in contact with a surface for an extended time may result in deterioration.

Specifications

Input sensitivity	50mV (1kHz)
Rated output	
Balanced	2.54V(1kHz)
Unbalanced	1.27V(1kHz)
Maximum output	
Balanced	12V(1kHz)
Unbalanced	6V(1kHz)
Gain *balanced input	
Balanced	34dB(1kHz)
Unbalanced	28dB(1kHz)
RIAA deviation	±0.2dB
THD (1kHz with 20kHz LPF)	
.....	0.03% (balanced 2.54V)
Power voltage.....	230V AC , 50Hz
Power consumption	
.....	19W (When no signal)
Maximum external dimensions	
.....	454 (W) x 189 (H) x 407 (D) mm
Weight	27kg



SOULNOTE, Inc.

<https://www.soulnote.link/>